

# Liberty Pumps®

## NEW!

## Ascent™

### **Macerating Toilet System**

**For addition of bathrooms below gravity drain lines. No need to break concrete floors.**

#### **Features:**

- Powerful & quiet macerator efficiently pumps waste up to 15' vertically and 150' away from soil stack.\*
- 3/4" or 1" discharge
- 115 volt operation
- Elongated white toilet with matching white pipe connectors
- 1.6 Gallons Per Flush
- Accepts additional fixtures such as a lavatory and shower
- Available with optional extension pipe for mounting flush behind wall
- Complies with American Disabilities Act (ADA) Height Guidelines and ANSI 117.1



\* Maximum head will vary depending on length of run and friction losses. Consult factory for proper pump sizing.

Complete system includes macerating unit, elongated toilet, flush valve and piping connector kit (toilet seat not included).



innovate. evolve.

# Ascent™ Macerating Toilet System

The Ascent™ macerating toilet system gives you the freedom to put a bathroom where you want it. Perfect for basements, garages and additions where gravity drain lines are not practical. The powerful but quiet macerator sits directly on the floor (or hidden behind a wall) and handles waste - pumping it through a small 3/4" or 1" diameter discharge line. Shipped with a hardware kit that includes white rubber pipe connectors for a more professional appearance.

## ASC-1 MACERATOR SPECIFICATIONS:

- 4/10 hp., 115 Volt, 5.2 amp, 60 HZ., 3450 RPM
- 4' White power cord
- Thermally protected – automatic reset
- Automatic level control switch
- Maximum fluid temperature: 104° F.
- Macerator tank material: Polypropylene, white
- Cutter: Stainless Steel
- 1-1/2" optional side inlets, slip connection
- 1-1/2" vent

Check valve included with hardware kit.

## TOILET SPECIFICATIONS:

- White, elongated bowl
- Complies with ADA height requirements
- Rear discharge
- 1.6 Gallons per flush
- Flush valve included



Models:	Description	Wgt.
<b>ASCENT</b>	Complete system: Macerator, toilet, flush valve and hardware kit	83 lbs.
<b>ASC-1</b>	Macerator unit and hardware kit	16 lbs.
<b>ASC-2</b>	Toilet tank with flush valve – white	27 lbs.
<b>ASC-3</b>	Toilet bowl, elongated – white	40 lbs.
<b>K001184</b>	Optional 4" extension pipe with seal. (For installation behind wall.)	2.5 lbs.

## PERFORMANCE CURVE

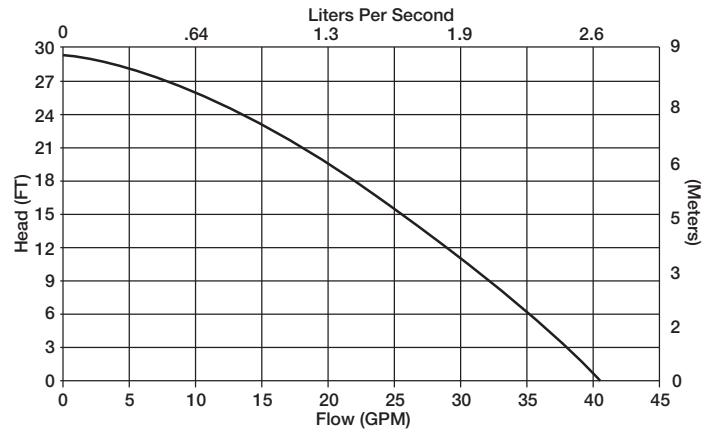

NOTE: Maximum shut-off head is 29 feet. Usable maximum head - assuming 150' of lateral discharge through 3/4" pipe is 15 feet. Consult factory for proper sizing and calculation of friction losses.

## DIMENSIONAL DATA

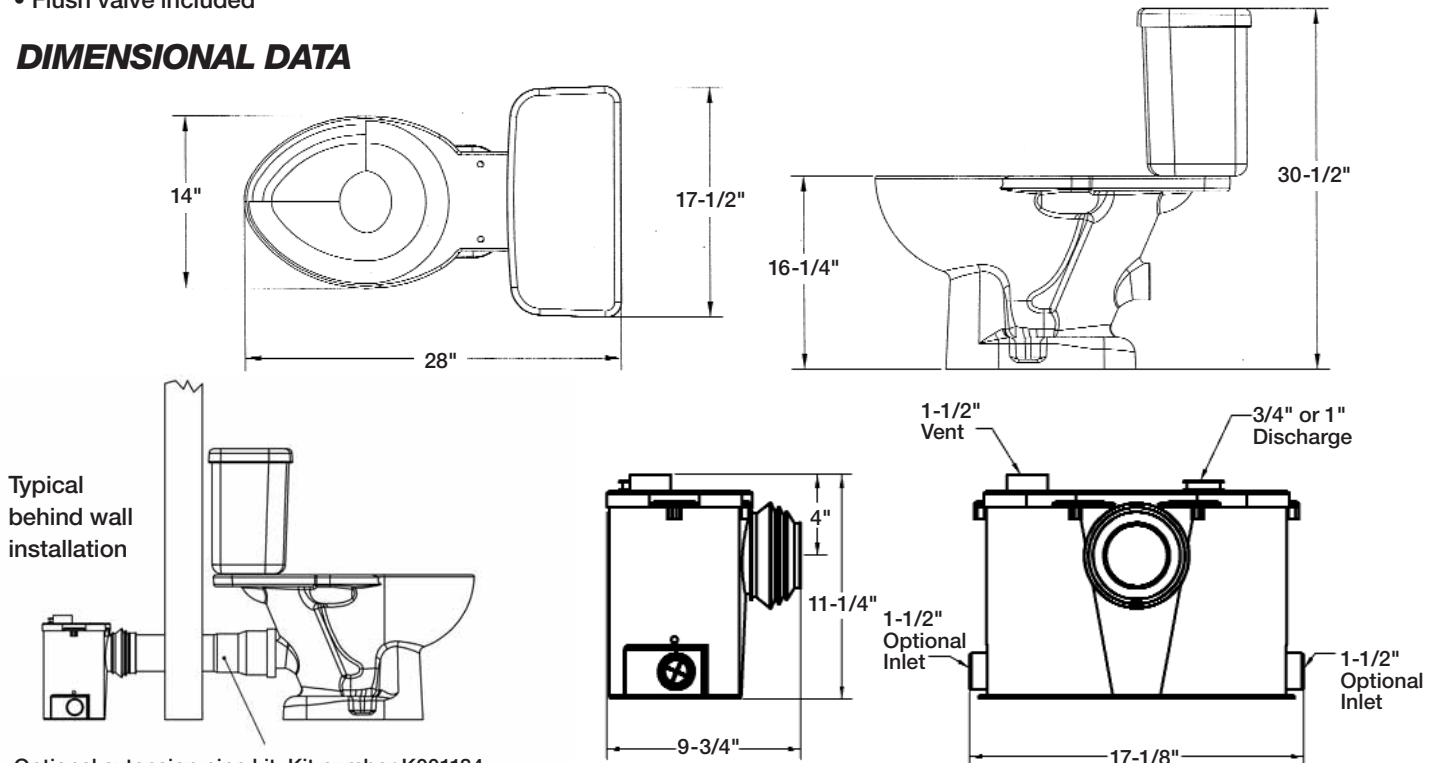

Optional extension pipe kit. Kit number K001184

Specifications subject to change without notice.